

Electric Feedthrough

The BG Service Co., Inc. introduces their line of electric feedthroughs for use in air-conditioning compressor, liquid filled transformer, and other services. The design includes one piece PTFE Teflon® insulation that has superior dielectric capability and no assembly or thermally sensitive joints. Engineering grade epoxy for ceramic-to-metal and solder for metal-to-metal joints make a highly reliable, leak proof sealing system¹. The BG design is more durable and has greater temperature capability than similar products ----- up to 250°F in operational service.

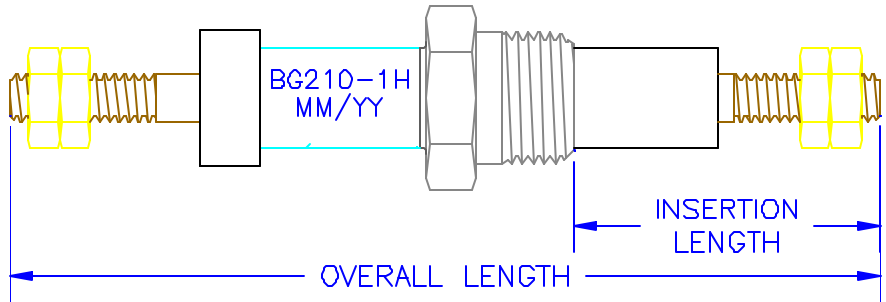

BG feedthroughs are built with copper conductors and brass nuts for maximum current carrying capability and the lowest connection losses. We electric test every feedthrough to assure integrity.

BG Model	Conductor	Current Rating Amps	Electric Flashover >	Mounting Thread, Hex	Overall Length	Insertion Length	Operating Pressure ^{1,2}	Brass Nut Installation ³	Maximum Operating Temp.
BG210-1H	0.25 in (6.35mm)	175	10kV	3/8-18 PTF-SAE Short, 13/16" Hex	4.45 in (113mm)	1.57 in (39.9mm)	500 PSIG (3445Kpa)	40 in-lb (4.5 N-m)	250°F (121°C)
BG230-1H				5/8-18 UNF-2A x .360 Lg. 13/16" Hex	4.45 in (113mm)	1.57 in (39.9mm)			
BG250LLH				1/2-14 NPT 7/8" Hex	5.17 in (131.3mm)	1.93 in (49mm)			
BG310H	3/4-14 NPT 1-1/8" Hex	5.22 in (132.6mm)	2 in (50.8mm)						
BG350H	.375 in (9.53mm)	275	12kV	7/8-14 UNF-2A x .475 Lg. 1-1/8" Hex	5.22 in (132.6mm)	2 in (50.8mm)		10 ft-lb (12.5 N-m)	

BG can engineer alternative conductor size, length, and mounting configurations to meet your specific needs.

The BG Service Co., Inc.
1400 Alabama Avenue
P.O. Box 2259
West Palm Beach, FL 33402-2259
Telephone: 561-659-1471
Fax: 561-659-1728
E-mail: sales@bgservice.com
Visit us at: www.bgservice.com

¹ Leak Rate: Test acceptance <1 x 10⁻⁶ cc/sec (He)

² Hydrostatic Pressure test 2500 PSI

³ Installation Note: Recommended installation torque for brass nuts should not be exceeded. Copper threads will be damaged. BG recommends the use of two wrenches when connecting to our feedthroughs. There are two brass nuts on each end that must be tightened against one another.